

# OPERATING MANUAL

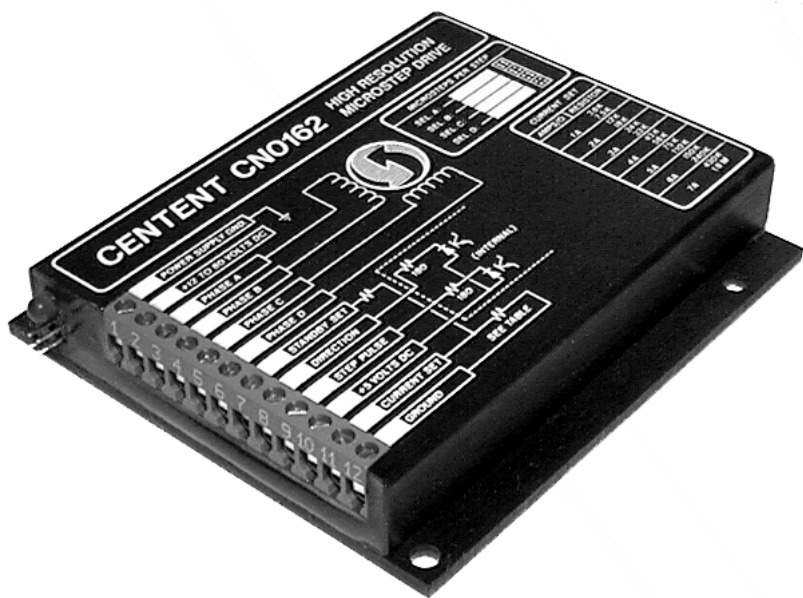

## CN0162 MICROSTEP DRIVE

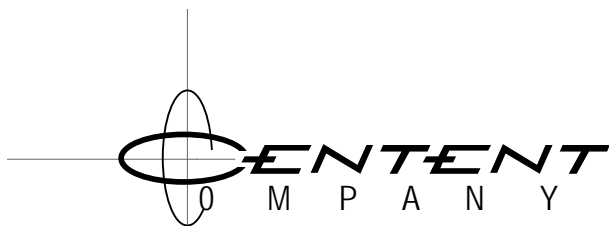

3879 SOUTH MAIN STREET 714-979-6491  
SANTA ANA, CALIFORNIA 92707-5710 U.S.A.

This manual contains information for installing and operating the following Centent Company products:

- CN0162 Microstep Drive

---

Centent and the Centent Company logo are trademarks of Centent Company. Other trademarks, tradenames, and service marks owned or registered by any other company and used in this manual are the property of their respective companies.

---

Copyright © 2011 Centent Company  
3879 South Main Street  
Santa Ana, CA 97207  
All Rights Reserved

# CONTENTS

---

## INTRODUCTION

|                              |   |
|------------------------------|---|
| GENERAL DESCRIPTION .....    | 3 |
| LOCATION OF COMPONENTS ..... | 4 |

## INSTALLATION

|   |    |
|---|----|
| POWER SUPPLY .....                                  | 5  |
| PHASE OUTPUTS .....                                 | 7  |
| MOTOR LEAD COLOR CODE TABLES .....                  | 10 |
| STANDBY SET .....                                   | 12 |
| DIRECTION .....                                     | 13 |
| STEP PULSE .....                                    | 13 |
| +5 VDC.....   | 14 |
| CURRENT SET .....                                   | 15 |
| CURRENT SET TABLE.....                              | 16 |
| RESOLUTION SELECT .....                             | 17 |
| RESOLUTION OPTIONS TABLE .....                      | 18 |
| MICROSTEP COMPENSATION (Offset Trimpot adjust)..... | 19 |

## FEATURES

|                             |    |
|-----------------------------|----|
| MICROSTEPPING.....          | 20 |
| ANTI-RESONANCE.....         | 21 |
| POWER-ON RESET.....         | 23 |
| UNDER-VOLTAGE LOCKOUT ..... | 23 |
| FAULT LED.....              | 24 |
| CHOPPING FREQUENCY .....    | 25 |
| CURRENT PROFILE OPTION..... | 25 |

## PERFORMANCE

|                                  |    |
|----------------------------------|----|
| MICROSTEP ACCURACY .....         | 27 |
| MOTOR TOLERANCES .....           | 27 |
| MOTOR LINEARITY .....            | 27 |
| MOTOR LOAD.....                  | 28 |
| TORQUE AND POWER .....           | 28 |
| MOTOR WINDING CONFIGURATION..... | 30 |
| POWER SUPPLY VOLTAGE.....        | 33 |
| POWER SUPPLY CURRENT .....       | 33 |
| MOTOR AND DRIVE HEATING .....    | 34 |

|                      |    |
|----------------------|----|
| SPECIFICATIONS ..... | 36 |
|----------------------|----|

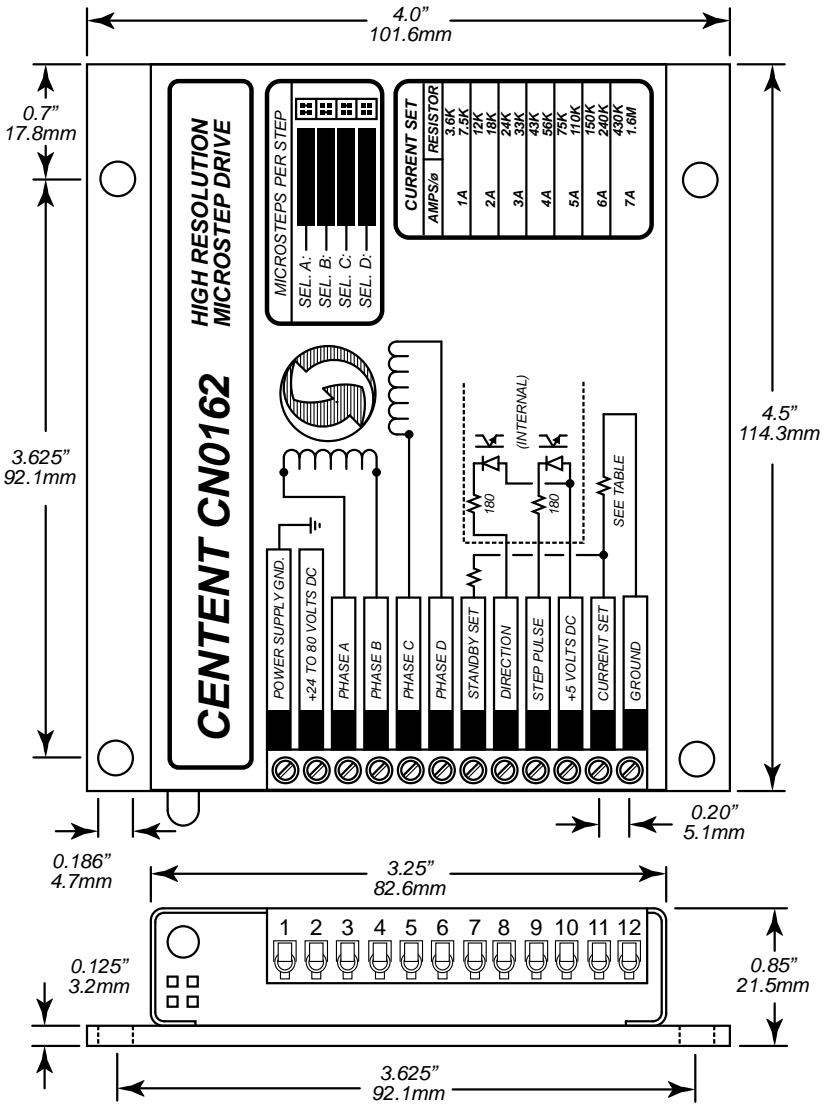

Figure 1: CN0162 MICROSTEP DRIVE (Actual Size)

## GENERAL DESCRIPTION

The CENTENT CN0162 is a high resolution step motor drive featuring four user selectable microstep resolutions. The resolution is selected by an option header on the front of the drive. Available step rates range from full-step to 256 microsteps. The CN0162 driver is capable of delivering up to 1.5 million microsteps per second to the step motor.

The CN0162 operates on an unregulated positive supply voltage of 12-80 VDC. Drive output current ranges from .1 to 7 amps per phase. The CN0162 operates hybrid PM step motors rated from .1 to 14 amps per phase. With suitably sized motors, over one-third horsepower (300 watts) can be delivered to the user's application.

The control interface for the drive is opto-isolated for maximum noise immunity. The inputs are compatible with TTL drivers and require no additional components.

Anti-resonance circuitry is employed in the CN0162 to provide mid-band stability. This allows continuous, full power operation at speeds normally prohibited by mid-band resonance. The pin-out of the driver is compatible with the CENTENT CN0142 and CN0143 microstep drives.

The 'H' bridge output utilizes MOSFET design to minimize heating due to switching losses. Automatic current standby reduces phase current to a low level while the motor is at rest to keep heating of the drive and motor to a minimum. To improve motor efficiency and high speed performance the CN0162 tracks the drive's chopping frequency to the power supply voltage. This permits the use of motors with winding inductance as low as 0.5 millihenry.

Over-current (winding shorts etc.), over-temperature (insufficient heat sinking), and under-voltage are automatically sensed by the CN0162. When any of these conditions occur the CN0162 shuts down and turns on a 'fault' LED to indicate the presence of the fault condition.

The drive is compact; measuring 4" x 4.75" x .85". It comes encapsulated in a heat conductive epoxy and encased in an anodized aluminum cover. The result is an environmentally rugged package that resists abuse and contamination.

## LOCATION OF COMPONENTS

The major components of the CN0162 are shown in **Figure 2**. The following is a description of these components.

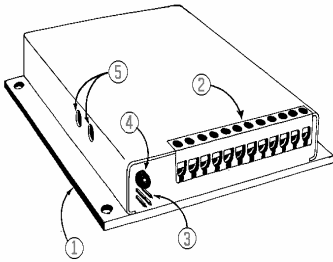

**Figure 2:** Component Location

### MOUNTING PLATE

This plate also serves as a heatsink for the drive. Primary heat generating components are attached to this plate. Secondary heat generators are thermally coupled to it by the heat conductive epoxy used to encapsulate the CN0162.

### CONNECTOR

A 12 position terminal strip located on the front edge of the CN0162 provides the connections for power supply, motor windings and controller interface. The function of each contact is printed on the case adjacent to the terminal strip.

### OPTION HEADER

This 4 pin header is used to select microstep resolution. The user jumpers the appropriate pins with the shorting bars supplied with the drive. Four resolutions are available in each drive. There are a total of 21 possible resolutions for the CN0162.

### FAULT LED

This LED indicates that the CN0162 has triggered its protective shutdown circuit. Cycling the power supply after correcting the fault condition will reset the CN0162 and turn off the LED.

### OFFSET TRIMPOTS

These two adjustment pots allow the user to trim the CN0162 to a particular step motor. This nulls out any residual step error and is especially effective at microstep resolutions of 16 or above.

## INSTALLATION

When operating the CN0162 at high power levels an external heatsink must be attached to the mounting plate. Optional heatsink kits in various configurations are available from Centent Company.

No terminals or connectors are required on the wiring to the drive. A wire size of 16-22 gauge is recommended. Either stranded or solid conductor wire may be used. The insulation should be stripped back .25 inches and the wire left untinned. The following section describes each connector terminal in detail.

## POWER SUPPLY

## TERMINAL 1 & 2

Terminal 1 is the ground connection. Terminal 2 connects to the positive output from the power supply. The power supply voltage range is +12 to +80 VDC. The power supply may be unregulated. For unregulated supplies it is recommended that the ripple voltage be limited to a maximum of 10% of the DC output voltage.

**The power supply terminals should have a capacitor of at least 470  $\mu\text{f}$  connected across them. This is particularly important for regulated power supplies since they usually have little output capacitance. This capacitor should be located as close to Terminals 1 & 2 as possible (see Figure 3,  $C_2$ ).**

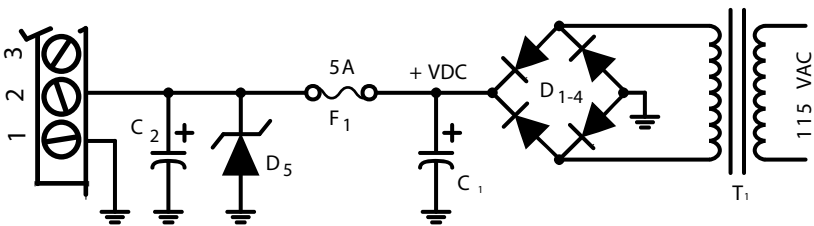

Figure 3: Power Supply

For those users that wish to build their own power supply, Figure 3 shows a suggested circuit. Because of the electrical noise generated by these drives, it is not recommended that the supply be shared with low level logic circuitry.

During rapid deceleration of large inertial loads from high speeds, step motors become generators of considerable electrical power. This is returned to the supply by the step motor drive. If the supply cannot absorb this power, the voltage generated may exceed the 80 volt limit of the CN0162 and damage the drive and power supply.

To prevent this problem a zener diode should be connected from Terminal 2 to ground (Figure 3, D<sub>5</sub>). This diode protects the drive from any over-voltage condition. Recommended diodes are 1N4762 (1 watt) or 1N5375 (5 watt). Note the 5 AMP fuse (F<sub>1</sub>) placed in series with Terminal 2 and the power supply. Be sure this fuse is located between the power supply and the zener diode. In the event of an over-voltage condition the zener diode and fuse may be destroyed, but the CN0162 and power supply will be protected from damage.

Power supply current requirements depend on the motor being used and whether it is wired for high performance (parallel) or low performance (series) operation. See MOTOR WINDING CONFIGURATION (page 30) in the PERFORMANCE section of this manual for a complete explanation of motor wiring options.

If the motor is wired for high performance (parallel) the current required from the supply will not exceed 2 / 3 of the motor's rated per phase current. Low performance (series) operation requires a maximum of 1 / 3 the motor's rated current. Use the manufacturer's phase current rating of the motor in conjunction with the motor wiring option to estimate the size of power supply required. As an example, a 6 wire motor rated at 4 amps per phase is used with the power supply circuit (in Figure 3) and the motor is in the full winding (series) configuration. To calculate the current required from the power supply:

$$I_{SUPPLY} = \frac{1}{3} \times 4 = 1.33 \text{ Amps}$$



In this example, assume a transformer with a 25 volt RMS secondary will be used. After rectification this will produce a 37 VDC power supply voltage. To calculate the size of the filter capacitor (Figure 3,  $C_1$ ) use the following equation:

$$C_1 = \frac{(83,333)(I_{SUPPLY})}{V_{SUPPLY}} = \frac{(83,333)(1.33)}{37} = 2995 \mu F \approx 3000 \mu F$$

$C_2$  (in Figure 3) is the 470  $\mu F$  capacitor that should be located close to the CN0162 power supply terminals.  $C_1$  may be made smaller by that amount if desired. Both capacitors must have a voltage rating safely in excess of the power supply voltage; 50 VDC being a good choice for this example.

More than one CN0162 can be run from a common power supply if the filter capacitor is sized large enough to account for the combined load. Each CN0162 must have separate power supply leads back to the power supply.

## PHASE OUTPUTS

## TERMINALS 3 - 6

These are the phase winding outputs to the step motor. One motor winding goes to PHASE A-B and the other motor winding connects to PHASE C-D. No power is applied to the Phase outputs until reception of the initial step pulse after power-up of the CN0162 (see page 23 - Power-On Reset).

The CN0162 will drive 4, 6 and 8 wire motors. With 6 wire and 8 wire motors, the user has the option of connecting the windings in a high or low performance configuration. References in this manual to full or half-winding configurations (6 wire motors) infers series or parallel configurations (8 wire motors) as well. A 4 wire motor is considered to be wired in the high performance configuration. See MOTOR WINDING CONFIGURATION (page 30) in the PERFORMANCE section of this manual to determine the best configuration for your application.

The high performance configuration in a 6 wire motor is called half winding or parallel operation. Half winding operation uses the center-tap wire and one end wire to constitute a winding (Figure 4). The other end wire of each winding is not used. In a 8 wire motor the windings are connected as pairs of parallel wired windings.

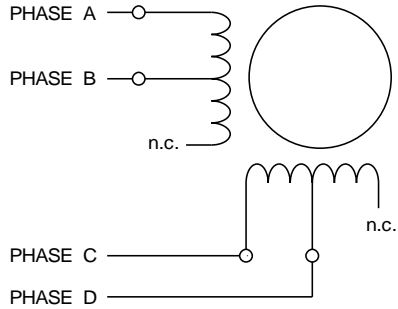

Figure 4: Half Winding

The low performance configuration in a 6 wire motor is called full winding or series operation. Only the end wires of each phase constitutes a winding (Figure 5). The center-taps are left unused. In a 8 wire motor the windings are connected as pairs of series wired windings.

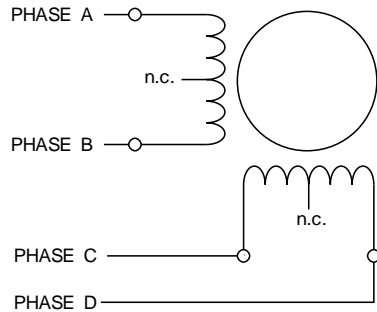

Figure 5: Full Winding

Table I & Table II (Page 10) show various manufacturer's 6 wire motor lead color codes and how they connect to the CN0162 for full winding and half winding operation. Table III & Table IV (Page 11) show various manufacturer's 8 wire motor lead color codes and how they connect to the CN0162 for series and parallel wired operation. Note that the wires in parentheses are connected to each other and not to a terminal on the CN0162. Wires not connected to the CN0162 should not be left exposed. Cut off the stripped ends and insulate them with electrical tape or heat-shrink tubing.

The CN0162 is a high frequency switching type drive. Because of the rapid rate of voltage and current change inherent with this type of drive, considerable RFI is generated. The following precautions should be taken to prevent noise from coupling back to the inputs and causing erratic operation.

- 1. Never run the motor leads in the same cable or wiring harness as the STEP, DIRECTION or +5 VDC input lines.**
- 2. Keep power supply leads as short as possible. If the power supply lead length exceeds 12 inches, use a .1  $\mu$ f capacitor across Terminals 1 & 2 at the drive.**
- 3. Never wire capacitors, inductors or any other components to the motor output terminals.**
- 4. Ground the CN0162 case.**
- 5. Ground the step motor case.**

**Table I: FULL WINDING OPERATION**

| <b>MANUFACTURER</b>       | <b>MOTOR TERMINAL</b> |        |         |        |
|---------------------------|-----------------------|--------|---------|--------|
|                           | 3                     | 4      | 5       | 6      |
| <b>SUPERIOR ELECTRIC</b>  | GRN/WHT               | GREEN  | RED/WHT | RED    |
| <b>RAPIDSYN</b>           | GRN/WHT               | GREEN  | RED/WHT | RED    |
| <b>IMC</b>                | GRN/WHT               | GREEN  | RED/WHT | RED    |
| <b>EASTERN AIR DEV.</b>   | GRN/WHT               | GREEN  | RED/WHT | RED    |
| <b>PACIFIC SCIENTIFIC</b> | BLACK                 | ORANGE | RED     | YELLOW |
| <b>WARNER ELECTRIC</b>    | BROWN                 | ORANGE | RED     | YELLOW |
| <b>VEXTA</b>              | BLUE                  | RED    | BLACK   | GREEN  |
| <b>JAPAN SERVO</b>        | BLUE                  | RED    | YELLOW  | GREEN  |

**Table II: HALF WINDING OPERATION**

| <b>MANUFACTURER</b>       | <b>MOTOR TERMINAL</b> |         |         |         |
|---------------------------|-----------------------|---------|---------|---------|
|                           | 3                     | 4       | 5       | 6       |
| <b>SUPERIOR ELECTRIC</b>  | WHITE                 | GREEN   | BLACK   | RED     |
| <b>RAPIDSYN</b>           | WHITE                 | GREEN   | BLACK   | RED     |
| <b>IMC</b>                | WHITE                 | GREEN   | BLACK   | RED     |
| <b>EASTERN AIR DEV.</b>   | WHITE                 | GREEN   | BLACK   | RED     |
| <b>PACIFIC SCIENTIFIC</b> | BLACK                 | ORG/BLK | RED     | RED/YEL |
| <b>WARNER ELECTRIC</b>    | BLACK                 | ORANGE  | RED     | WHITE   |
| <b>VEXTA</b>              | BLUE                  | WHITE   | YELLOW  | GREEN   |
| <b>JAPAN SERVO</b>        | BLUE                  | WHITE * | WHITE * | GREEN   |

\* White wires are not interchangeable, use ohm meter to find white-blue and white-green pairs.

**Table III: SERIES WINDING OPERATION**

| <b>MANUFACTURER</b>       | <b>MOTOR TERMINAL</b> |          |                   |          |
|---------------------------|-----------------------|----------|-------------------|----------|
|                           | <b>3</b>              | <b>4</b> | <b>5</b>          | <b>6</b> |
| <b>SUPERIOR ELECTRIC</b>  | RED                   | RED/WHT  | GREEN             | GRN/WHT  |
|                           | (BLACK-WHITE)         |          | (ORANGE-BLK/WHT)  |          |
| <b>PACIFIC SCIENTIFIC</b> | BLACK                 | ORANGE   | RED               | YELLOW   |
|                           | (BLK/WHT-ORG/WHT)     |          | (RED/WHT-YEL/WHT) |          |
| <b>BODINE</b>             | BROWN                 | ORANGE   | RED               | YELLOW   |
|                           | (BRN/WHT-ORG/WHT)     |          | (RED/WHT-YEL/WHT) |          |
| <b>PORTESCAP</b>          | BROWN                 | ORG/WHT  | RED               | YEL/WHT  |
|                           | (BRN/WHT-ORANGE)      |          | (RED/WHT-YELLOW)  |          |
| <b>DIGITAL MOTOR</b>      | BLACK                 | ORANGE   | RED               | YELLOW   |
|                           | (BLK/WHT-ORG/WHT)     |          | (RED/WHT-YEL/WHT) |          |

**Table IV: PARALLEL WINDING OPERATION**

| <b>MANUFACTURER</b>       | <b>MOTOR TERMINAL</b> |          |          |          |
|---------------------------|-----------------------|----------|----------|----------|
|                           | <b>3</b>              | <b>4</b> | <b>5</b> | <b>6</b> |
| <b>SUPERIOR ELECTRIC</b>  | RED                   | BLACK    | GREEN    | ORANGE   |
|                           | WHITE                 | RED/WHT  | BLK/WHT  | GRN/WHT  |
| <b>PACIFIC SCIENTIFIC</b> | BLACK                 | BLK/WHT  | RED      | RED/WHT  |
|                           | ORG/WHT               | ORANGE   | YEL/WHT  | YELLOW   |
| <b>BODINE</b>             | BROWN                 | BRN/WHT  | RED/WHT  | RED      |
|                           | ORG/WHT               | ORANGE   | YELLOW   | YEL/WHT  |
| <b>PORTESCAP</b>          | BROWN                 | BRN/WHT  | RED      | RED/WHT  |
|                           | ORANGE                | ORG/WHT  | YELLOW   | YEL/WHT  |
| <b>DIGITAL MOTOR</b>      | BLACK                 | BLK/WHT  | RED      | RED/WHT  |
|                           | ORG/WHT               | ORANGE   | YEL/WHT  | YELLOW   |

**STANDBY SET****TERMINAL 7**

This output implements the automatic standby feature of the CN0162. By reducing the phase current to a lower, 'standby' level the drive system operates cooler during periods of motor inactivity. Heating of the motor, drive, and power supply are kept to a minimum by utilizing this option.

The amount of current reduction is adjustable from 0% to 100% of normal operating current. A resistor is connected from the STANDBY SET output to the CURRENT SET input (Terminal 7 to Terminal 11) to set the current reduction.

The value of the STANDBY SET resistor is calculated from the following two equations:

$$R_{PARALLEL} = \frac{(47,000)(I_{STANDBY})}{7.2 - I_{STANDBY}}$$

Where  $R_{PARALLEL}$  is the resistance required at Terminal 11 to set the desired standby current,  $I_{STANDBY}$ . This is the parallel combination of the existing CURRENT SET resistor,  $R_{SET}$ ; and the yet to be calculated STANDBY SET resistor,  $R_{STANDBY}$ .

$$R_{STANDBY} = \frac{(R_{PARALLEL})(R_{SET})}{R_{SET} - R_{PARALLEL}}$$

Where  $R_{STANDBY}$  is the resistor that will go between Terminal 7 and Terminal 11. Negligible power is involved; so a 1/4 watt resistor is fine.

When the motor has stopped for more than .1 seconds, the STANDBY SET output grounds  $R_{STANDBY}$ , effectively placing it in parallel with  $R_{SET}$ . This lowers the total resistance at the CURRENT SET input. Motor phase current is restored to its normal level 2 milliseconds after the next STEP pulse is received. Standby current reduction is not recommended when operating at less than 10 pulses/sec. (to prevent a reduction in operating current between input pulses).

If no current reduction is desired during standby, the STANDBY SET output is not connected. If 0% of normal current (freewheeling) is desired during standby, short Terminal 7 to Terminal 11.

## **DIRECTION**

## **TERMINAL 8**

Terminal 8 is the DIRECTION input. This input is sampled by the CN0162 on every step pulse input to determine which direction the motor will move.

The setup time for this input is 10 microseconds. This means the DIRECTION input must be correct 10 microseconds before the step pulse is issued. If the DIRECTION input is changed simultaneously with the low to high transition of the step pulse the direction will not change until the next step pulse.

The CN0162 employs an optocoupler to isolate the DIRECTION input from the driver's power supply. The user must provide a +5 VDC supply to operate the optocoupler circuit. This permits the use of current sink drivers, such as TTL logic or open collector transistors, to operate the input. The current requirement is 16 milliamps, which is compatible with standard TTL outputs.

## **STEP PULSE**

## **TERMINAL 9**

Microstepping in the CN0162 occurs on both edges of the step pulse input. This is done to improve motor smoothness at low speeds.

The current is changed in the PHASE A-B motor winding on the leading edge of the step pulse. The current is changed in the PHASE C-D motor winding on the trailing edge of the step pulse. The result is a smoothness equivalent to a drive operating at twice the selected microstep resolution.

This improvement comes for 'free', since the pulse rate is half of what would normally be required to achieve a given level of smoothness. The effect is most pronounced when the input is driven by 50% duty cycle pulses. The improvement is negligible when driven by very narrow (low duty cycle) pulses.

The CN0162 employs an optocoupler to isolate the STEP PULSE input from the driver's power supply. The user must provide a +5 VDC supply to operate the optocoupler circuitry. This permits the use of current sink drivers, such as TTL logic or open collector transistors, to operate the input. The current requirement is 16 milliamps, which is compatible with standard TTL outputs. The maximum STEP PULSE rate is 1.5 Mhz. The minimum on or off time is 300 nanoseconds. There are no rise or fall time limits.

**+5 VDC****TERMINAL 10**

This is the common anode terminal for the STEP PULSE and DIRECTION optocoupler LEDs. An external +5 VDC supply is connected to this terminal to provide the source of LED current for the Step Pulse and Direction inputs. If both are on, 32 mA of current is required from the +5 VDC supply. The LEDs have antiparallel connected diodes across them for protection against inadvertent polarity reversal.

If power supply voltages higher than 5 VDC must be used, the STEP PULSE and DIRECTION inputs require additional series resistance to limit currents to a 16 milliamps level. The following equation determines the value for these resistors:

$$R = \left( \frac{(V - 1.5)}{.016} \right) - 180$$

For example, if a +12 volt supply is to be used:

$$R = \left( \frac{(12 - 1.5)}{.016} \right) - 180 = 656.25 - 180 = 476.25 \approx 470 \Omega$$

(place a 470 ohm resistors in series with each input)

**DO NOT PUT RESISTORS IN SERIES WITH THE +5 VDC TERMINAL.**



**CURRENT SET****TERMINAL 11 & 12**

The CURRENT SET input determines the magnitude of the motor phase currents. This is done by connecting a 1/4 watt resistor between Terminals 11 & 12. Terminal 11 is the CURRENT SET input and Terminal 12 is the ground reference.

**Do not use Terminal 12 for power supply ground; Terminal 1 is power supply ground.**

The resistor value for phase current for a motor in the high performance configuration is derived using the following equation:

$$R_{SET} = \frac{(47,000)(I_{SET})}{7.2 - I_{SET}}$$

Where  $R_{SET}$  is the current set resistor and  $I_{SET}$  is the desired current.

Table 5 (page 16) lists resistor values rounded off to the nearest 5% standard resistors for both high performance (half winding) and low performance (full winding) operation.

**Use the half winding values for operating 4 wire motors.**

The maximum phase current of 7.2 amps is obtained with no CURRENT SET resistor (Terminal 11 voltage equals 2.5 volts), Zero phase current occurs with CURRENT SET shorted to ground (Terminal 11 voltage equals 0 VDC).

THE CN0162 DEFAULTS TO ITS MAXIMUM CURRENT OF 7.2 AMPS PER PHASE IF NO CURRENT SET RESISTOR IS PRESENT. THIS MAY CAUSE DAMAGE TO A MOTOR THAT IS TOO SMALL FOR THIS CURRENT LEVEL.

For best low speed smoothness, the motor phase current should not differ from the manufacturer's rating by more than  $\pm 20\%$ . Currents substantially above or below this may affect microstep accuracy and increase low speed vibration.

| <b>CURRENT SET TABLE</b>           |                                  |                                |
|------------------------------------|----------------------------------|--------------------------------|
| <b>MODE OF OPERATION</b>           |                                  | <b>RESISTOR</b>                |
| <b>HALF WINDING<br/>(PARALLEL)</b> | <b>FULL WINDING<br/>(SERIES)</b> | <b>STANDARD ±5%<br/>(OHMS)</b> |
| 0.1 A                              | 0.2 A                            | 680                            |
| 0.2 A                              | 0.4 A                            | 1.3 K                          |
| 0.3 A                              | 0.6 A                            | 2.0 K                          |
| 0.4 A                              | 0.8 A                            | 2.7 K                          |
| 0.5 A                              | 1.0 A                            | 3.6 K                          |
| 0.6 A                              | 1.2 A                            | 4.3 K                          |
| 0.7 A                              | 1.4 A                            | 5.1 K                          |
| 0.8 A                              | 1.6 A                            | 5.6 K                          |
| 0.9 A                              | 1.8 A                            | 6.8 K                          |
| 1.0 A                              | 2.0 A                            | 7.5 K                          |
| 1.25 A                             | 2.5 A                            | 10 K                           |
| 1.50 A                             | 3.0 A                            | 12 K                           |
| 1.75 A                             | 3.5 A                            | 15 K                           |
| 2.00 A                             | 4.0 A                            | 18 K                           |
| 2.25 A                             | 4.5 A                            | 22 K                           |
| 2.50 A                             | 5.0 A                            | 24 K                           |
| 2.75 A                             | 5.5 A                            | 30 K                           |
| 3.00 A                             | 6.0 A                            | 33 K                           |
| 3.25 A                             | 6.5 A                            | 39 K                           |
| 3.50 A                             | 7.0 A                            | 43 K                           |
| 3.75 A                             | 7.5 A                            | 51 K                           |
| 4.00 A                             | 8.0 A                            | 56 K                           |
| 4.25 A                             | 8.5 A                            | 68 K                           |
| 4.50 A                             | 9.0 A                            | 75 K                           |
| 4.75 A                             | 9.5 A                            | 91 K                           |
| 5.00 A                             | 10.0 A                           | 110 K                          |
| 5.25 A                             | 10.5 A                           | 130 K                          |
| 5.50 A                             | 11.0 A                           | 150 K                          |
| 5.75 A                             | 11.5 A                           | 180 K                          |
| 6.00 A                             | 12.0 A                           | 240 K                          |
| 6.25 A                             | 12.5 A                           | 300 K                          |
| 6.50 A                             | 13.0 A                           | 430 K                          |
| 6.75 A                             | 13.5 A                           | 680 K                          |
| 7.00 A                             | 14.0 A                           | 1.6 M                          |

**Table V: CURRENT SET TABLE**

The CURRENT SET input may also be driven by external circuitry such as operational amplifiers. In this case motor phase current is a linear function of the voltage on Terminal 11. Exceeding 2.5 VDC on Terminal 11 may result in permanent damage to the drive.

The CURRENT SET input is used in conjunction with the STANDBY SET input to provide current reduction while the drive is idle. See STANDBY SET, page 12 for details.

Phase current reduction can also be achieved by switching in an external parallel resistance. The circuit in Figure 6 shows how optically isolated standby torque and freewheeling functions may be implemented.

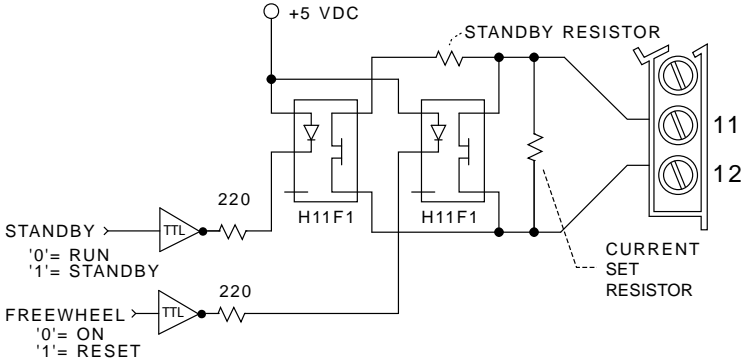
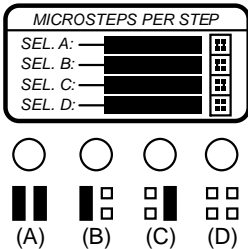

Figure 6: External current standby

**RESOLUTION SELECT**

**OPTION HEADER**

The OPTION HEADER is used to select the microstep resolution from the four available in each drive. It is located on the face of the drive, beneath the FAULT LED. Jumpers are installed as shown in Figure 7.



The resolution for each selection is printed on the case of the CN0162. To select a microstep resolution, install jumpers in the following manner:

- SEL. A: both jumpers installed
- SEL. B: left jumper only
- SEL. C: right jumper only
- SEL. D: no jumpers required

Figure 7: Option Header

Twenty-one different microstep resolutions are available in the CN0162. The drive is supplied to the user with 4 of the 21 available. Not all combinations of step resolutions are possible. Table VI may be used to determine the available combinations. The CN0162 is delivered as Option A, B, C or D. All four step resolutions for a given CN0162 must be selected from the same column (A, B, C or D) of Table VI.

It is permissible to switch the OPTION HEADER dynamically. The shorting bars may be replaced with TTL compatible drivers to allow the user to change the microstep resolution while the motor is running. Switching must occur at the full step location to maintain accurate step position.

An example of this would use a high resolution at low speed, and switch to a medium or low resolution during acceleration and high speed. This would keep the step rates at relatively low frequencies during the entire operation cycle while maintaining maximum smoothness at low speeds.

|                 |      | OPTION |   |   |   |
|-----------------|------|--------|---|---|---|
|                 |      | A      | B | C | D |
| STEP RESOLUTION | full | ●      | ● | ● | ● |
|                 | half | ●      | ● | ● | ● |
|                 | 4    |        | ● | ● | ● |
|                 | 5    | ●      |   | ● | ● |
|                 | 8    |        | ● | ● | ● |
|                 | 10   | ●      |   | ● | ● |
|                 | 16   |        | ● | ● | ● |
|                 | 20   |        |   | ● | ● |
|                 | 25   | ●      |   | ● |   |
|                 | 32   |        | ● |   | ● |
|                 | 40   |        |   | ● | ● |
|                 | 50   | ●      |   | ● |   |
|                 | 64   |        | ● |   | ● |
|                 | 80   |        |   | ● | ● |
|                 | 100  |        |   | ● |   |
|                 | 125  | ●      |   |   |   |
|                 | 128  |        | ● |   | ● |
|                 | 160  |        |   |   | ● |
|                 | 200  |        |   | ● |   |
|                 | 250  | ●      |   |   |   |
|                 | 256  |        | ● |   |   |

**Table VI:** Resolution Options

As well as choosing the step resolutions available in the driver, the user may specify the phase current profile for each selection. This is done to compensate for non-linearity in microstep step size at high resolutions. For more information, see CURRENT PROFILE OPTION (page 25).

## MICROSTEP COMPENSATION

## OFFSET TRIMPOTS

The offset trimpots provide compensation for the distortion that occurs to microstep size near the half-step location. Residual full step cyclic errors, a function of power supply voltage, motor phase inductance and phase current magnitude, cause the uneven microstep size. These errors can be canceled with the OFFSET TRIMPOTS.

The magnitude of the untrimmed error is on the order of  $1/16$  of a full step, so it is unlikely to be noticeable at resolutions less than 16 microsteps. Trimming is unnecessary at resolutions below 10 microsteps. Compensation is disabled at the half-scale position of the trimpot. The screwdriver slot in the trimpot is vertical at the half-scale position.

The left trimpot compensates the PHASE A-B outputs while the right trimpot compensates the PHASE C-D outputs. There are two methods for trimming the CN0162 to a motor and power supply. Both methods require the motor and power supply to be connected to the CN0162.

The RESET METHOD depends on the CN0162's power-on reset behavior, i.e. the drive does not apply power to the motor windings until a step pulse is received. Any holding torque the motor has when powered up is due to offset errors. This may be compensated as follows.

### *RESET METHOD:*

- 1. Turn both trimpots to the midrange position*
- 2. Cycle (Reset) the power supply*
- 3. Adjust left trimpot for minimum holding torque*
- 4. Adjust right trimpot for minimum holding torque*

The RUN METHOD depends on trimming out vibration; the observable manifestation of offset errors. This requires a 250 Hz source connected to the STEP PULSE input. A function generator set to +5 and -5 voltage levels is suitable for this purpose.

### *RUN METHOD:*

- 1. Set both trimpots to mid-scale*
- 2. Turn on the power, apply the 250 Hz source*
- 3. Adjust the left trimpot for minimum vibration*
- 4. Adjust the right trimpot until all vibration stops*

## MICROSTEPPING

## FEATURES

Microstepping is a technique that electronically multiplies the number of steps a motor takes per revolution. This is useful because it increases motor angular resolution and decreases motor vibration. A 200 step per revolution motor, operated at 100 microstep resolution, will take 20,000 microsteps to complete one revolution of the motor shaft.

The twenty-one different resolutions available in a CN0162 are represented in Table VI as the column designated STEP RESOLUTION.

Microstepping is normally accomplished by driving the motor windings with sine and cosine weighted currents. A 90 degree electrical angle change in these currents results in a mechanical angle movement of 1.8 degrees (full step) in a 200 step/revolution motor. The sine-cosine values may be replaced with values compensated for a specific motor type or characteristic. See CURRENT PROFILE OPTION (page 25) for further information on compensated current profiles.

Low speed vibration results from the start-stop or incremental motion of the motor. This generates periodic acceleration and deceleration reaction torques at the step rate. When the step rate matches, or is a sub-harmonic of the mechanical resonant frequency of the motor, the vibrations become severe.

Microstepping divides full step positioning into small 'microsteps', thus decreasing the magnitude of the reaction torques generated. This results in a commensurate decrease in resonant vibration.

Another benefit of microstepping is an increase in the number of resolvable angular positions. However, there are a number of factors which limit the achievable open-loop accuracy of these positions (See page 27 - MICROSTEP ACCURACY, for further details).

## ANTI-RESONANCE

Most step motors are prone to parametric instability or resonance when rotating at a rate of 4 to 15 revolutions per second. Called mid-band instability or resonance, the phenomenon manifests itself as a torsional oscillation of 50 to 150 Hz when the motor is running in this speed range. The torsional oscillation has a tendency to increase in amplitude with time until it reaches a peak equal to the step angle. When this happens, the motor loses synchronization and stops.

Generally the amplitude buildup takes from tens to hundreds of cycles to reach this level, so several seconds may elapse from the start of the oscillation until the motor stops. Usually this is long enough to allow the motor to accelerate through this region. However, continuous operation in this speed band is impossible.

Above and below this range of speeds, the oscillation amplitude may not be sufficient to stop the motor but it is still present. Figure 8 shows the parametric resonance frequency versus motor step rate for three unrelated step motors. In all three cases resonance breaks out at 1000-1400 (full) steps per second and is most severe at the higher torsional frequencies (lowest step rates).

Because any torsional oscillation implies acceleration and deceleration of a mass, torque that otherwise would have been available for useful work is wasted to sustain this oscillation.

The CN0162 incorporates a mid-band anti-resonance compensation circuit that closes the loop on this instability and electronically damps it out. Since the motor is now unable to sustain oscillation, torque previously wasted is now available.

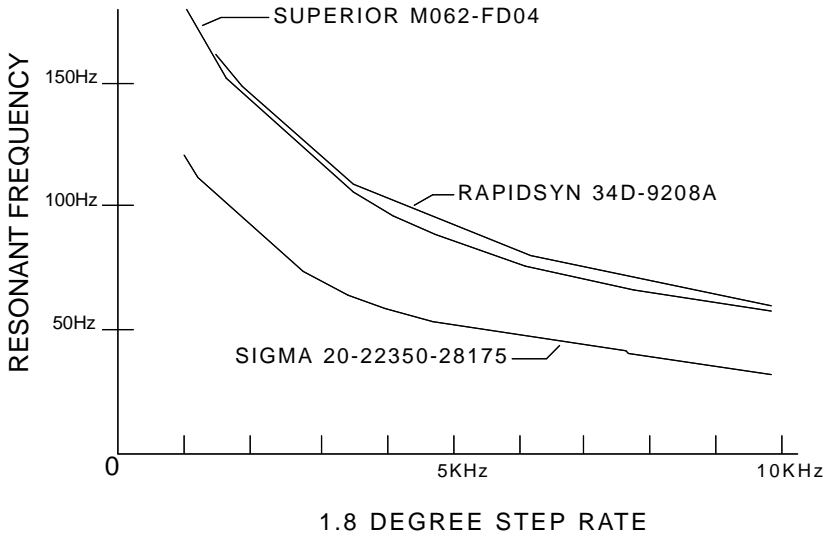

Figure 8: RESONANCE

With anti-resonance circuitry the motor may be run continuously at speeds where de-synchronization would otherwise occur. The motor no longer exhibits 'forbidden' regions where continuous-operation cannot be sustained. And there is more torque available over the entire operating range of the drive.

The operation of the anti-resonance circuit in most applications is transparent to the user, in the sense that no special provisions have to be taken to accommodate it. There are two instances where anti-resonance may be disadvantageous.

#### 1. VERY HIGH SPEED

The anti-resonance circuit limits the maximum speed to 50,000 full steps per second. Should it be necessary to run the motor faster than that, a special 'anti-resonance disabled' version of the step motor drive can be ordered (a SUPERIOR ELECTRIC ME61-8001 will exceed 150,000 full step per second or 45,000 RPM).



## 2. VERY LARGE INERTIAL LOAD

Microstepping permits reliable operation with inertial loads in excess of 100 times the motor's moment of inertia. However very large inertial loads so lower the mechanical resonant frequency that the anti-resonance circuit may cause oscillation. It may be better to order the drive without the circuit since resonance usually is not a problem with moderate to large inertial loads anyway.

### POWER-ON RESET

The Power-on Reset circuitry of the CN0162 insures that the drive turns on in an organized manner. All internal counters and other circuits are held in a reset state until the power supply voltage rises to a safe operating level.

The threshold for operation is 11.75 VDC. Power-on Reset is released on the first step pulse after the power supply rises above this threshold. **Until receipt of the first step pulse the motor windings carry no current and the motor has no holding torque.** The Phase outputs are active however, and carry a high frequency square-wave equal in voltage to the power supply.

After receiving the first step pulse, the drive delivers full holding torque and the motor is located at the first microstep position; PHASE A-B outputs are at maximum current while PHASE C-D outputs are at minimum current.

### UNDER-VOLTAGE LOCKOUT

Under-voltage Lockout protects the CN0162's output transistors from damage resulting from low power supply voltage. This feature activates when the power supply voltage drops below 11.75 volts. Below this voltage, the Phase outputs (Terminals 3, 4, 5, 6) are pulled low. Supply current is removed from the output transistors and the motor stops positioning. When the power supply voltage falls below 5 volts, the Phase outputs go open circuit and float.

While the CN0162 is in an under-voltage condition, the drive is held in the reset state. Once the power supply voltage rises above 11.75 volts and all internal voltages have stabilized to their proper levels, a Power-on Reset is automatically executed.

## FAULT LED

The CN0162 incorporates protective circuitry to guard the drive against potentially destructive conditions. An electronic 'circuit breaker' is tripped when fault conditions are sensed. The Fault LED illuminates to indicate that the CN0162 has shut down. This may be due to either an over-temperature or an over-current condition.

While shut down, the drive's Phase outputs (Terminals 3, 4, 5, 6) are taken to 0 volts. This action removes all current from the motor windings, thus protecting the output transistors. Although no power supply current flows, the motor is difficult to turn because the windings are shorted together. The drive is held in a reset condition to minimize the quiescent current draw. This keeps power dissipation to a minimum, allowing the fastest possible cooling of the drive.

Power supply voltage must be removed and reapplied to reset the 'circuit breaker' and extinguish the Fault LED.

The CN0162 has a sensor that trips the protection circuit when the case temperature exceeds 70°C. The drive will not operate after it has cooled down. The power supply must be 'recycled' to operate the drive. If a CN0162 has shut down due to overheating, the cause is usually an inadequate heatsink. Do not continue to operate the drive until adequate heat sinking has been provided. Repeated shut-down due to overheating will result in permanent damage to the CN0162 drive.

The other cause of protective shutdown is an over-current condition. The CN0162 will shut down on Phase output to ground shorts, phase to phase shorts (shorted windings), cross-wired windings and windings with insufficient inductance (shorted turns).

The over-current sensor trips the protection circuit any time a Phase output current exceeds 10 amps for 2  $\mu$ S. This rapid response to over-current conditions insures the safety of the Phase output transistors. Once shut down, the CN0162 will not operate, even if the fault condition has cleared. The power supply must be recycled to reset the protection circuit.

If a CN0162 has shut down due to an over-current condition, determine the cause and correct it before recycling the power supply, otherwise it will simply shut down again. Overheating shutdowns can be distinguished from over-current shutdowns by observing the case temperature of the CN0162. Over-current conditions will shut down the drive before high case temperatures can occur. If the CN0162 repeatedly shuts down and the cause is not obvious, change motors. The cause may be an inter-winding short in the motor.

Although the protection circuitry of the CN0162 is extensive, it cannot prevent damage under all destructive conditions. Excessive power supply voltage and a short between a Phase output and the positive power supply input are but two examples of conditions that may damage the driver. The CN0162's protection circuitry should not be considered as a substitute for proper operating procedures.

## **CHOPPING FREQUENCY**

To improve motor efficiency, the CN0162 automatically adjusts its chopping frequency to be proportional to power supply voltage. This means the motor ripple current is independent of power supply voltage. Motor hysteresis losses are reduced and less motor heating results. Because of this, very low inductance motors may be used, yielding better high speed performance.

The chopping frequency is 1 KHz per volt in the CN0162. The chopping frequency ranges from 12 KHz to 80 KHz over the entire power supply voltage range. The minimum recommended motor winding inductance is 500 microhenrys. Consult Centent Company about operation of motors with less than 500 microhenrys of inductance.

## **CURRENT PROFILE OPTION**

Microstepping is achieved by varying the currents in the motor's phase windings in a continuous and cyclic manner. Sine-cosine weighed currents provide the first approximation of a linear relationship between the (electrical) angle of the phase currents and the (mechanical) angle of the motor.

Most step motors have a residual non-linearity in the electrical to mechanical angle function. This means a microstep taken near the motor's full-step location will not have the same angular displacement as one taken near the half-step location. This trait is specific to a motor type or model.

The non-linearity can be canceled by distorting the sine-cosine currents to match the characteristics of the motor. This compensated current profile is then substituted for the standard sine-cosine profile in the CN0162's ROM.

Centent Company has a test stand specifically designed to generate compensated current profiles. It accommodates all size 23, 34 and 42 motors and some smaller sizes as well. For a non-reoccurring engineering fee, Centent will generate a profile tailored to a customer submitted motor. The result is the highest obtainable open loop positioning accuracy for that motor.

The microstep resolutions for compensated profiles are the same as those available for the standard sine-cosine version of the drive. It is also possible to order a CN0162 with different current profiles at the same microstep resolution. The option header would then choose between motor types rather than resolutions. Any combination of resolution and current profile (motor type) is possible, as long as all resolutions are selected from the same option column of Table VI.

**MICROSTEP ACCURACY****PERFORMANCE****MOTOR TOLERANCES**

Most step motors are specified as having a  $\pm 5\%$  non-accumulative step tolerance. This implies that a 200 step per revolution motor will have an absolute accuracy of 1 part out of 2000.

If the motor is run open-loop (as most step motors are) the user cannot expect to position a motor accurately at anything greater than a 10 microstep resolution. Consequently higher step resolutions, in open-loop applications, only contribute to motor smoothness.

**MOTOR LINEARITY**

For every motor there is a function that relates the angle of rotation to the electrical angle of the winding currents. If it were directly proportional, then sine-cosine varying currents would cause a uniform rate of rotation, resulting in uniformly spaced microsteps.

For most motors this function resembles Figure 9. The motor current profile must be distorted from the sine-cosine profile to compensate for non-linearity. The effectiveness of this will determine the microstep position accuracy.

The electrical to mechanical angle function is dependent on motor current. By varying the value of the current set resistor, it may be possible to trim out residual positional error. Should this be inadequate, Centent can generate a compensation profile for motors of a like model number or type. This custom profile is 'programmed' into the customer's CN0162. See CURRENT PROFILE OPTION (page 25) for details.

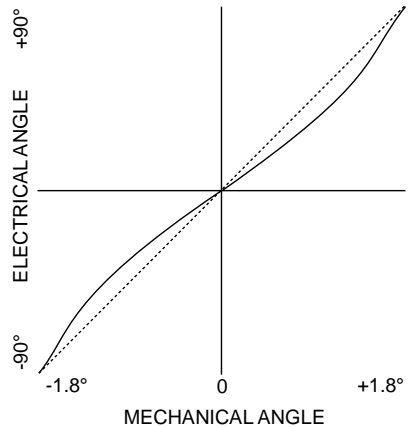

Figure 9: Motor linearity

## MOTOR LOAD

Generally speaking, motor load is the single most significant contributor to microstep positioning error. A step motor only generates torque when a rotor error angle exists. The relationship between rotor displacement angle and restoring torque for a typical motor is shown in Figure 10.

The function that relates error angle to torque is approximately sinusoidal. An error angle equal to one microstep occurs when motor load equals the holding torque divided by the microstep resolution. If the motor load is transient or due to acceleration, the rotor error will decrease to a residual level upon removal of that transient.

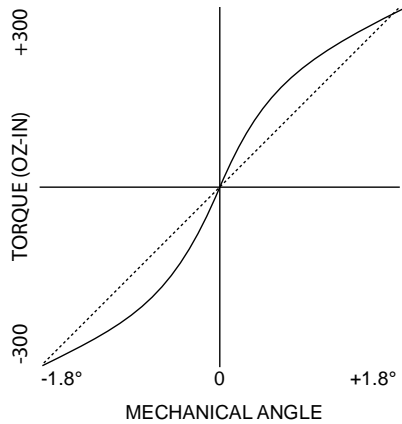

Figure 10: Torque vs. rotor angle

## TORQUE AND POWER

Step motor performance curves exhibit two distinct regions with respect to speed. In Region 1 (Figure 11, page 29), motor torque is constant with speed while motor shaft power is proportional to speed. In Region 2, motor torque decreases as the inverse of the speed while motor shaft power remains constant.

The current set resistor determines motor torque in Region 1. Motor torque is held constant by controlling the magnitude of the motor phase current. The step rate in Region 1 is low enough to permit motor phase current to reach the programmed value.

In Region 1 motor torque is nearly proportional to motor current. Torque remains constant until it intersects the motor's load line, which may be approximated with the equation:

$$T = \frac{kV}{f \sqrt{L}}$$

where:  $T$  = torque

$k$  = motor constant  $V$  = power supply voltage

$f$  = steps per second  $L$  = motor inductance

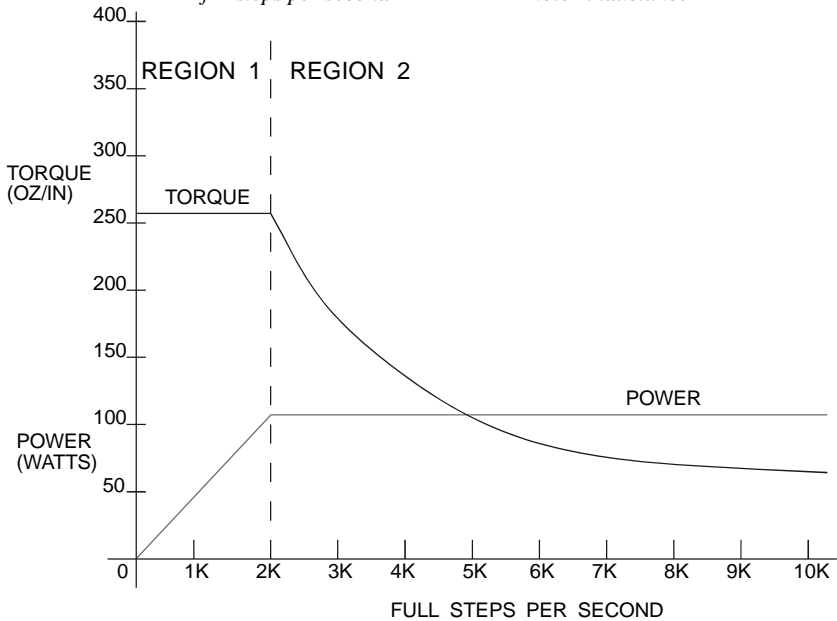

Figure 11: Torque & power vs. speed

The intersection of the constant torque line and the motor load line marks the beginning of Region 2. Above this speed motor torque is not dependent on the value of the current set resistor.

As the motor enters Region 2 torque begins to drop off as the inverse of the speed. Motor winding inductance limits the rate of current rise, and as speed increases, progressively less current can be forced into the windings. Because motor torque is proportional to phase current, and current (in Region 2) is proportional to the step period, torque decreases as the inverse of the step rate.

Because power is the product of speed and torque, power would remain constant (in Region 2) in an ideal step motor. In a real step motor there are speed related power losses (i.e. friction, magnetic losses, windage and other losses) that result in a shallow slope to the power curve. The intersection of this slope and the speed axis determines the maximum speed of the motor.

**THE CENTENT CN0162 DRIVE IS CAPABLE OF RUNNING STEP MOTORS AT SPEEDS HIGH ENOUGH TO CAUSE DAMAGE TO MOTOR SHAFT BEARINGS.**

## **MOTOR WINDING CONFIGURATION**

The customer has the option (with 6 or 8 wire motors) of connecting the windings in a high or a low performance configuration. High performance operation has twice the maximum motor power output of low performance operation. The speed to which constant torque is maintained is also doubled. This performance improvement comes at the expense of greater motor and drive heating.

The low performance configuration is called full-winding operation in 6 wire motors and series operation in 8 wire motors. Similarly, the high performance configuration is called half-winding operation in 6 wire motors and parallel operation in 8 wire motors.

Performance in a 6 wire, full winding configuration will match that of an 8 wire, series connected motor with a similar current rating. Performance in a 6 wire, half winding configuration will be equivalent to that of an 8 wire, parallel connected motor with a similar phase current rating. References to full or half-winding configuration infers series or parallel configuration (for 8 wire motors) as well.

If a 6 wire motor is used in the full winding configuration, the supply current will not exceed  $1/3$  of the motor's rated per phase current. The current draw of a 6 wire motor in the half winding configuration will not exceed  $2/3$  of the motor's per phase current rating.



Motor torque is approximately proportional to motor current multiplied by the number of winding turns that carry the current. In full-winding operation, twice the number of turns carry current as in half-winding operation, so only half the current is needed to generate a given level of torque. Unfortunately full-winding operation quadruples the effective winding inductance. In Region 2, motor power is proportional to the inverse of the square root of the winding inductance.

Figure 12 (Page 32) illustrates the effect of various winding currents on motor performance. A 4 Amp per phase motor was driven from 1 to 6 Amps per phase in 1 Amp increments.

Note that if the motor in Figure 12 is operated in excess of 4000 steps/sec., the current set resistor value would make no difference in performance. What would be significant is the reduction in low speed heating of the motor and drive evident at the lower current setting.

Figure 13 (page 32) illustrates the effects of full vs. half winding operation at low and high power supply voltages. Note that full-winding operation at 54 VDC yields performance virtually identical to half-winding operation at 27 VDC.

Full-winding configuration is preferred for Region 1 operation, and is suitable for Region 2 if the power available is sufficient. The benefits are low motor and drive heating and modest power supply current requirements. For full-winding operation the phase current level of the CN0162 is set to one-half the motor's nameplate phase current rating.

The half-winding configuration doubles high speed torque. Motor phase currents are twice those in a full-winding connected motor. This doubles power supply requirements and thus results in hotter motor and drive temperatures. For high performance operation the phase current level of the CN0162 is set to the motor's nameplate phase current rating.

**Holding torque and low speed torque are the same in half-winding and full-winding configurations.**

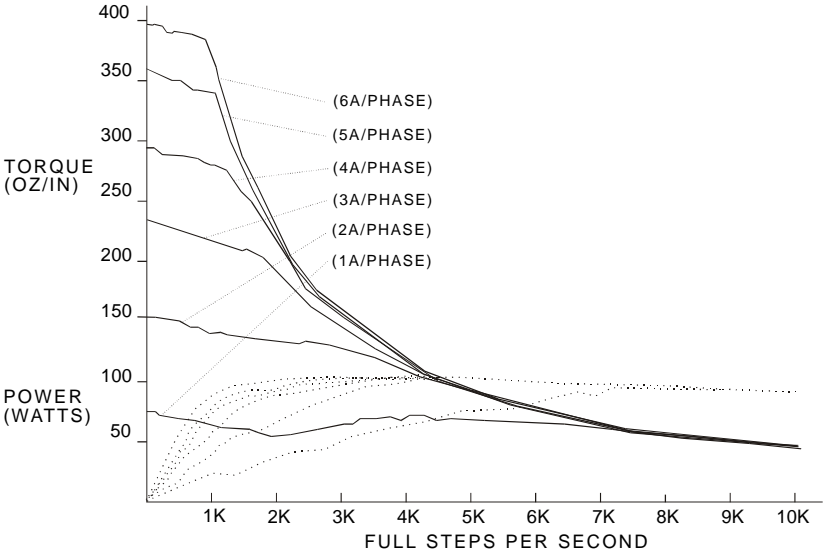

Figure 12: Winding current vs. torque

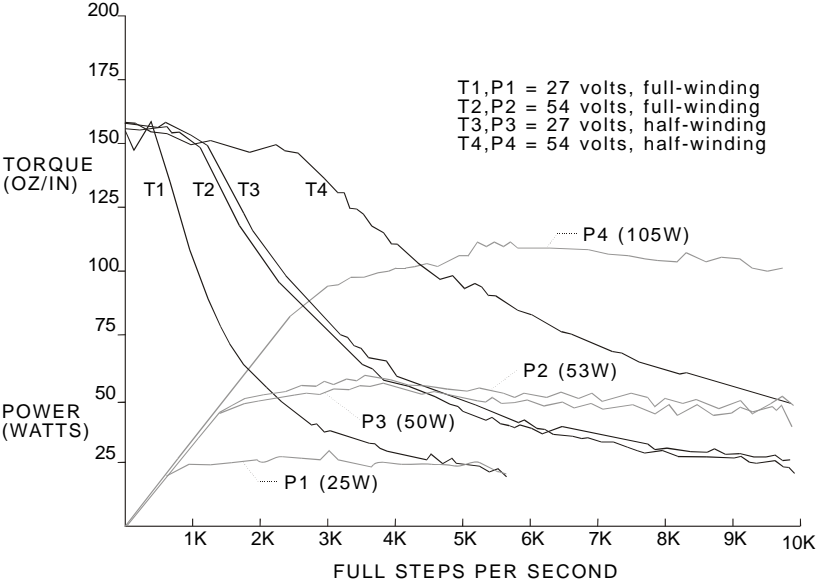

Figure 13: Half vs. Full winding operation

## POWER SUPPLY VOLTAGE

The choice of power supply voltage affects the power a step motor generates in Region 2. The speed to which constant torque is maintained is proportional to power supply voltage. Consequently maximum motor shaft power is also proportional to the power supply voltage.

The CN0162 step motor drive has a power supply range from 12 to 80 VDC. This results in a motor power range of 6.6:1.

Increasing power supply voltage increases motor heating. Taking this into consideration, the choice of power supply voltage should be just high enough to meet the application's power requirements and no higher.

## POWER SUPPLY CURRENT

Power supply current depends on the current set resistor value, the speed the motor is running and the load applied to the motor.

Generally speaking, the power supply current for a full-winding configured motor will not exceed  $1/3$  the motor's rated per phase current. A half-winding configured motor will require no more than  $2/3$  the rated per phase current.

Figure 14 shows the power supply current for a motor wired in the half-winding configuration. The solid curve is for unloaded operation; the dotted curve is for fully loaded operation.

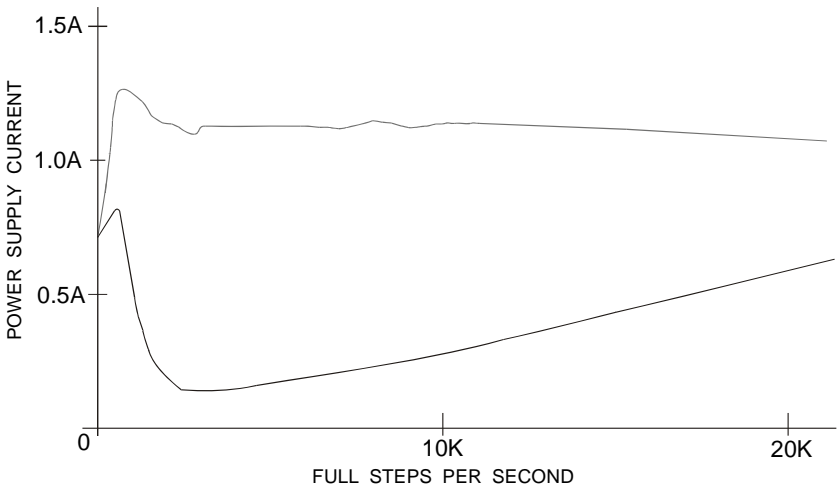

Figure 14: Power supply current

## MOTOR AND DRIVE HEATING

Motor and drive heating is equivalent to the difference between the electrical power input and the motor's mechanical power output. The ratio of output power to input power is the system efficiency.

The power losses are dependent on motor speed, load and winding configuration, the power supply voltage, current set and other factors. The power losses in a step motor drive are primarily resistive and therefore easy to calculate. Each channel of the drive may be considered to be equivalent to a .55 ohm resistor.

Step motor drive current dissipation in Region 1 is always considerably higher than in Region 2. In Region 1, motor phase currents, and therefore drive channel currents are sinusoidal. The peak amplitude is equal to the rated per phase current in the half-winding mode and half of that in the full-winding mode. In Region 1, power dissipation may be calculated as follows.

$$\omega = (I_{\phi})^2$$

*half-winding operation:*

$$\omega = .55 \left( \frac{I_{\phi}}{2} \right)^2$$

*full-winding operation:*

Note that the power dissipation is 4 times higher for the half-winding connection. In Region 2 power dissipation may be calculated as follows.

$$\omega = 1.1 \left( \frac{I_{\phi}}{6} \right)^2$$

*half-winding operation:*

$$\omega = 1.1 \left( \frac{I_{\phi}}{3} \right)^2$$

*full-winding operation:*

Region 1 power dissipation is 4.5 times greater than Region 2 power dissipation. If the motor will spend most of its time stopped or in Region 1, use Region 1 power dissipation equations to evaluate the needs for heat sinking. Also consider utilizing the STANDBY SET feature (see page 12) to reduce power dissipation while the motor is idle.

The protection provided by the internal temperature sensor of the CN0162 is not designed as a substitute for adequate heat sinking. Repeatedly tripping the Fault indicator by allowing the drive to overheat induces thermal stress that will eventually lead to failure of the CN0162 drive.

Generally, if the CN0162 is too hot to touch, additional cooling is required. The case temperature of the drive should never under any circumstance be allowed to exceed +70 degrees C (+158 degrees F).

As a practical guide, heat sinking will be necessary if the drive is operated at 3 amps or more. Heat sink material should be aluminum or copper, not steel, wood or composite. Clean the mating surfaces between drive and heat sink of dirt, grease or paint. Use of a commercial transistor heat sink compound will further enhance the dissipation of heat from the CN0162 drive.

Centent Company manufactures finned heat sink kits for the CN0162 High Resolution Microstep Drive. Several mounting configurations are available to accommodate the user's requirements. Contact Centent Company for details and ordering information.

## SPECIFICATIONS

### ELECTRICAL

| GENERAL             | MIN | MAX | UNITS |
|---------------------|-----|-----|-------|
| Resolution          | 1   | 256 | μStep |
| Supply voltage      | 12  | 80  | VDC   |
| Current (no motor)  | 50  | 60  | Ma    |
| PWM frequency       | 12  | 80  | Khz   |
| Motor inductance    | .5  | --  | mH    |
| Motor phase current | .1  | 7   | A     |

### STEP PULSE INPUT

|                    |     |     |      |
|--------------------|-----|-----|------|
| Logic '1' voltage  | 1.8 | 5.0 | VDC  |
| Logic '0' current  | 12  | 20  | mA   |
| Pulse width 'high' | 300 | --  | nSec |
| Pulse width 'low'  | 300 | --  | nSec |
| Rise time          | --  | --  | --   |
| Fall time          | --  | --  | --   |
| Frequency          | --  | 1.5 | Mhz  |

### DIRECTION INPUT

|                   |     |     |     |
|-------------------|-----|-----|-----|
| Logic '1' voltage | 1.8 | 5.0 | VDC |
| Logic '0' current | 12  | 20  | mA  |

### ENVIRONMENTAL

|                       |     |     |    |
|-----------------------|-----|-----|----|
| Operating temperature | -20 | +75 | °C |
| Humidity              | 0   | 100 | %  |
| Shock                 | --  | 100 | G  |

### MECHANICAL

|                       |                   |     |       |
|-----------------------|-------------------|-----|-------|
| Weight                | 17                | 19  | oz.   |
| Terminal Screw Torque |                   | 4.5 | lb/in |
| Mounting screw size   | 6                 | 8   | #     |
| Size (L x W x H)      | 4.75 x 4.0 x 0.85 |     | in.   |
| Mounting hole centers | 3.625 x 3.625     |     | in.   |

Centent Company manufactures a complete line of step motor products. In addition to the CN0162 high resolution microstep drive, the following drives are designed to serve a wide variety of motors and applications. They all share the compact, rugged design characteristics of the CN0162.

- CN0124 half step drive - *motors up to 2 amps/phase*
- CN0142 10 microstep - *motors up to 3.6 amps/phase*
- CN0143 10 microstep - *motors up to 7.2 amps/phase*
- CN0152 full/half step - *motors up to 3.6 amps/phase*
- CN0153 full/half step - *motors up to 7.2 amps/phase*
- CN0165 microstep step - *motors up to 10.0 amps/phase*

Centent complements their driver series with a family of step motor controllers and indexers. These controllers may also be used with other manufacturer's drives. They are packaged in the same distinctive style of anodized aluminum covers as the Centent step motor drives.

- CN0170 - *2 axis intelligent controller with RS-232 interface*
- CN0172 - *preset indexer (DIP switch & potentiometer inputs)*
- CN0173 - *step pulse generator (panel mounted)*

For product information, availability and pricing of any of the above drives and controls contact:

CENTENT COMPANY  
3879 SOUTH MAIN STREET  
SANTA ANA, CALIFORNIA, 92707, U.S.A.

TELEPHONE: 714-979-6491